

# INSTALLATION GUIDELINES FOR RIGID CONDUIT

## CUTTING

No special tools are required to cut Royal Rigid PVC Conduit. It can easily be cut with a hacksaw, a fine-toothed handsaw or PVC conduit cutters. For conduit with more than a 2-inch diameter, use a miter box or saw guide to ensure a square cut. Deburr the end using a knife or file.

## BENDING

It may be necessary to create bends in the field by heating and deforming rigid conduit. To accomplish this, the following guidelines should be followed:

- For heating the rigid conduit, use a heat gun or some other flameless heat source. Do not use an open flame to heat the conduit. The rigid conduit must be heated to approximately 260°F in order to bend without kinking.
- Heat a length of conduit equal to approximately 10 times the rigid conduit nominal diameter.
- Once the rigid conduit has been adequately heated, bend it to the required angle plus 3 extra degrees. The additional angle will accommodate the "spring back" which will occur during cooling.
- After bending of the conduit is completed, immediately cool the bend using water or cold air.
- According to the National Electrical Code (NEC), the minimum bending radius for rigid conduit is as shown in the table below.

NOMINAL SIZE (IN)	MIN. RADIUS TO CENTER OF CONDUIT OR TUBING (IN)
1/2"	4.016
3/4"	4.489
1"	5.748
1 1/4"	7.244
1 1/2"	8.268
2"	9.488
2 1/2"	10.512
3"	12.992
3 1/2"	14.606
4"	15.984
5"	24.016
6"	30.000

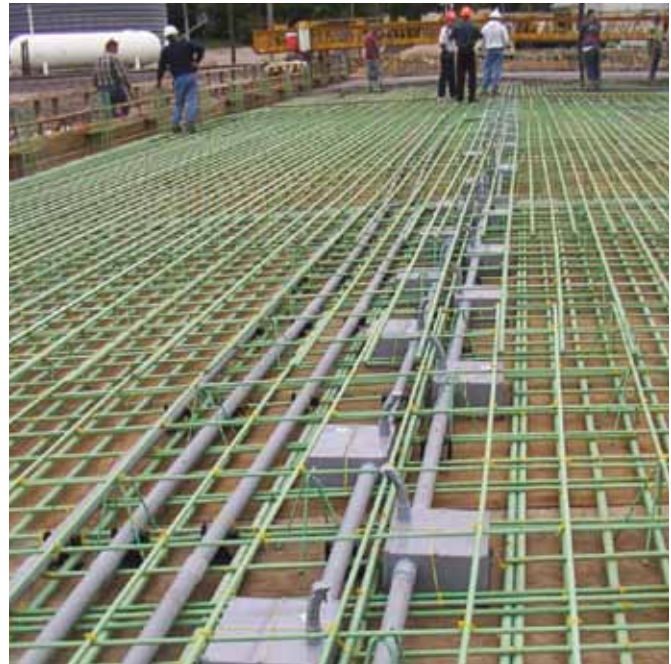

# INSTALLATION GUIDELINES FOR RIGID CONDUIT

## PROCEDURE FOR SOLVENT WELDING JOINTS

- Use solvent cement and primer prior to expiration date marked on container.

- Above 32°F ambient temperature, joints may be assembled without the use of primer, provided adequate penetration and softening of the pipe/fitting surface can be achieved with solvent cement alone.

**1.** Assemble materials for the job, including correct solvent cement, primer and correctly sized applicator.

**2.** Cut pipe as square as possible using a hand saw and miter box or mechanical saw. Do not use a diagonal cut, as it reduces the bonding area in the joint.

**3.** If plastic tubing cutters are used, care must be taken to remove any raised bead at the end of the pipe, caused by cutting. A file or reamer may be used to remove the bead.

**4.** Use a knife, file or reamer to remove burrs from the inside and outside of the pipe end, as these will hinder the integrity of the joint. All sharp edges should be removed from the inside and outside edges of the pipe to prevent the pipe from pushing the solvent cement into the fitting socket, thereby causing a weak spot to form. The pipe end should be chamfered, as shown below.

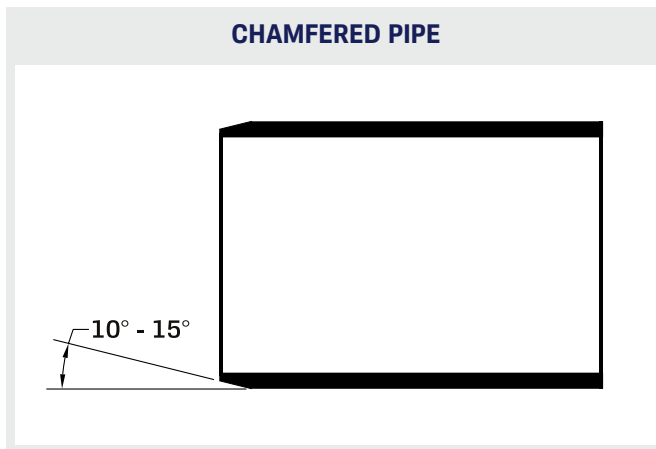

**5.** All dirt, grease and moisture should be removed from the pipe and socket by thoroughly wiping with a clean, dry cloth.

**6.** Dry fit pipe and fitting joints prior to cementing. For proper interference fit, the pipe should go easily into the socket approximately 1/3 to 2/3 of the socket depth. If this is not the case, other pipe or fittings should be used.

**7.** The applicator should be sized according to the size of pipe and fittings being joined. The brush width of the applicator should be equal to approximately 1/2 of the pipe diameter.

**8.** Primer is used to penetrate and soften the surfaces so that they will fuse together under a wide variety of conditions. The penetration or softening can be checked by dragging the edge of a knife or sharp object over the coated surface. If a few thousandths of an inch of the primed surface can be scratched or scraped away, proper penetration has occurred. Varying weather conditions affect priming and cementing action and may require more time or repeated applications to either or both surfaces.

**9.** If using primer, use the correct applicator size and aggressively work the primer into the socket, keeping the surface and applicator wet until the surface has softened, re-dipping the applicator as required. When the surface is primed, remove any puddles of primer from the socket.

**10.** Aggressively work the primer on to the end of the pipe, to a point 1/2" beyond the depth of the socket.

**11.** Perform a second application of primer in the socket.

**12.** While the surfaces are still wet, the appropriate solvent cement should be applied.

**13.** Using the correct applicator size, aggressively work a full, even layer of cement onto the pipe end to a point equal to the depth of the socket. Do not brush out to a thin paint type layer, as this will dry within a few seconds.

**14.** Aggressively work a medium layer of cement into the fitting socket; avoid puddling cement in the socket. On the pipe end, do not coat beyond the socket depth or allow cement to run down into the pipe beyond the socket.

**15.** Apply a second full, even layer of cement on the pipe.

**16.** Immediately, while the cement is still wet, assemble the joint. Use enough force to ensure that the pipe is fully inserted into the socket. Twist the pipe a 1/4 turn as it is being inserted.

**17.** Hold the joint together for approximately 30 seconds to avoid push out.

**18.** After assembly, inspect the joint to ensure that there is a ring or bead of cement completely around the juncture of the pipe and socket. If there are voids in this ring, sufficient cement was not applied and the joint may be defective.

# INSTALLATION GUIDELINES FOR RIGID CONDUIT

**19.** Remove the excess cement from the pipe and socket (including the ring or bead) using a cloth. Avoid disturbing or moving the joint.

**20.** Handle newly cemented joints with care until initial set has taken place. Follow set and cure times before handling or testing the system.

## SOLVENT CEMENTING

All connections should be made using and applying solvent cement.

### SET TIMES AVERAGE INITIAL SET TIMES

TEMPERATURE RANGE	PIPE SIZES 1/2" to 1 1/4"	PIPE SIZES 1 1/2" to 2"	PIPE SIZES 2 1/2" to 6"
59° to 104° F	2 min	5 min	30 min
41° to 59° F	5 min	10 min	2 hrs
3° to 41° F	10 min	15 min	12 hrs

### JOINT CURE SCHEDULE AVERAGE JOINT CURE TIMES

TEMPERATURE RANGE DURING ASSEMBLY & CURE PERIODS	PIPE SIZES 1/2" to 1 1/4"	PIPE SIZES 1 1/2" to 2"	PIPE SIZES 2 1/2" to 6"
59° to 104° F	2 min	5 min	30 min
41° to 59° F	5 min	10 min	2 hrs
3° to 41° F	10 min	15 min	12 hrs

In damp or humid weather allow 50% more cure time.

### ESTIMATED SOLVENT CEMENT REQUIREMENTS AVERAGE NUMBER OF JOINTS PER QUART OF SOLVENT CEMENT

PIPE / FITTING DIAMETER	1/2"	3/4"	1"	1 1/2"	2"	2 1/2"	3"	4"	6"
NUMBER OF JOINTS	550	360	280	150	80	70	60	50	24

## SOLVENT CEMENTING IN COLD WEATHER

- Store pipe and fittings in a heated area. Prefabricate as much of the system as possible in a heated area.
- When not in use, store sealed solvent cement and primer between 41°F and 70°F. Do not use open flame or electric heaters to warm cements and primers.
- Take care to remove moisture, ice and snow from the mating surfaces.

## SOLVENT CEMENTING IN HOT WEATHER

- At the time of assembly, the surface temperature of the mating surfaces should not exceed 113°F. Shade or shelter the joint surfaces from direct sunlight for at least 1 hour prior to joining and during the joining process. If necessary, swab the mating surfaces with clean, wet rags to reduce the surface temperature (thoroughly dry surfaces before applying primer or cement).

- Make joints during the cooler early morning hours.
- Apply cement quickly and join pipe to fitting as quickly as possible after applying the cement.

- Keep solvent cement container closed or covered when not in use, to minimize solvent loss.

## SOLVENT CEMENTING IN WET CONDITIONS

- Mating surfaces must be dry when the joint is made.
- Work under a cover or canopy to keep rain off pipe and fittings.
- Work quickly after drying the pipe and fitting to avoid condensation.
- Allow a longer cure time before the system is tested or used.

## STORAGE AND HANDLING OF SOLVENT CEMENT AND PRIMER

- Solvent cement and primer contain highly flammable solvents. Follow all specific safety precautions provided on container label and Material Safety Data Sheet.

# INSTALLATION GUIDELINES FOR RIGID CONDUIT

- Keep primer and solvent cement away from heat, sparks and open flame.
- Keep containers tightly closed except when in use.
- Ensure proper ventilation of work area and avoid inhaling solvent vapors.
- Where the possibility of splashing exists, wear proper eye protection or a face shield.
- Avoid contact with skin.

## SUPPORT STRAPS

Rigid PVC conduit must be supported with straps when installed in above ground applications. These straps should be installed snugly, while allowing linear movement of the conduit. See the table below for recommended maximum spacing of support straps.

**MAXIMUM RECOMMENDED SPACING OF SUPPORT STRAPS**

NOMINAL SIZE (IN)	NEC RECOMMENDED SPACING (FT)
1/2"	3
3/4"	3
1"	3
1 1/4"	5
1 1/2"	5
2"	5
2 1/2-3"	6
3 1/2-5"	7
6"	8

## STORING CONDUIT AND FITTINGS

Store conduit and fittings at the same temperature, otherwise they may expand and contract at different rates and become incompatible.

## MAXIMUM OPERATING AND AMBIENT TEMPERATURES

When installing conduit according to the National Electrical Code (NEC), Royal PVC Conduit can be used with up to 90°C (194°F) wiring.

Royal Electrical Solutions Rigid PVC Conduit and fittings can be installed in locations with an ambient temperature not exceeding 122°F.

## EXPANSION JOINTS

According to the National Electrical Code, if the amount of expansion expected due to temperature variance during and after construction is more than 1.8", expansion joints must be used. Royal Electrical Solutions recommends the use of expansion joints whenever the expected temperature change is greater than 25°F.

## EXPECTED EXPANSION

The coefficient of linear expansion for PVC Rigid Conduit is as follows:

$$3 \times 10^{-5} \text{ in (expansion/contraction) / in (pipe length) / }^{\circ}\text{F (change in temperature)}$$

## NOTE

The following chart shows the amount of expansion expected with various pipe lengths/temperature changes. If the rigid conduit is installed in an exposed location, 30°F should be added to the amount of temperature change ( $\Delta T$ ) due to the effects of radiant heat.

## REQUIRED NUMBER OF EXPANSION JOINTS

The following table shows the amount of travel that is available with each trade size of Royal Electrical Solutions Rigid conduit expansion joints:

**EXPANSION/CONTRACTION OF PVC (IN) PER 10 FT LENGTH OF PIPE RUN**

$\Delta T (^{\circ}\text{F})$	5	10	15	20	25	30	35	40	45	50
<b>5</b>	0.01	0.02	0.03	0.04	0.05	0.05	0.06	0.07	0.08	0.09
<b>10</b>	0.02	0.04	0.05	0.07	0.09	0.11	0.13	0.14	0.16	0.18
<b>15</b>	0.03	0.05	0.08	0.11	0.14	0.16	0.19	0.22	0.24	0.27
<b>20</b>	0.04	0.07	0.11	0.14	0.18	0.22	0.25	0.29	0.32	0.36
<b>25</b>	0.05	0.09	0.14	0.18	0.23	0.27	0.32	0.36	0.41	0.45
<b>30</b>	0.05	0.11	0.16	0.22	0.27	0.32	0.38	0.43	0.49	0.54
<b>35</b>	0.06	0.13	0.19	0.25	0.32	0.38	0.44	0.50	0.57	0.63
<b>40</b>	0.07	0.14	0.22	0.29	0.36	0.43	0.50	0.58	0.65	0.72
<b>45</b>	0.08	0.16	0.24	0.32	0.41	0.49	0.57	0.65	0.73	0.81
<b>50</b>	0.09	0.18	0.27	0.36	0.45	0.54	0.63	0.72	0.81	0.90

# INSTALLATION GUIDELINES FOR RIGID CONDUIT

## REQUIRED NUMBER OF EXPANSION JOINTS

PART NUMBER	DESCRIPTION ALLOWANCE (IN)	TRAVEL (IN)
E016050	1/2" Expansion Joint	4
E016075	3/4" Expansion Joint	4
E016100	1" Expansion Joint	4
E016125	1 1/4" Expansion Joint	4
E016150	1 1/2" Expansion Joint	4
E016200	2" Expansion Joint	4
E016250	2 1/2" Expansion Joint	4
E016300	3" Expansion Joint	8
E016350	3 1/2" Expansion Joint	8
E016400	4" Expansion Joint	8
E016500	5" Expansion Joint	8
E016600	6" Expansion Joint	8

The required number of expansion joints can be calculated using the following formula:

### EXPANSION JOINT FORMULA

$$\# \text{ Expansion Joints Required} = \frac{\text{Total Expected Amount of Expansion (in)}}{\text{Expansion Joint Travel Allowance (in)}}$$

The number of expansion joints calculated above should be rounded up to the nearest whole number.

## SETTING THE PISTON OPENING

Expansion joints must be installed such that they allow for both expansion and contraction of the conduit. The piston of the expansion joint must be set at the correct position to allow for this linear movement. To determine the correct position for the piston at the time and temperature of installation, the following formula should be used:

### PISTON OPENING

$$\text{Piston Setting (in)} = \frac{(\text{Max. Temp. (}^\circ\text{F)} - \text{Install. Temp. (}^\circ\text{F)})}{\text{Total Expected Temperature Change (}^\circ\text{F)}} \times \left[ \text{Expansion Joint Expansion Allow (in)} \right]$$

## INSTALLATION GUIDELINES

- Securely fasten the expansion joint barrel so that it does not shift. Loosely connect the conduit so that it is free to move.
- To function properly, expansion joints should be installed near a fixed point.
- It is better to use more expansion joints than not enough, since problems are difficult to correct after conductors and wires have been pulled through the conduit.
- Ensure that the barrel and piston are aligned and level.
- For vertical installations of expansion joints, have the barrel running down with the piston at the bottom to prevent dirt and water from getting inside the joint and causing it to malfunction.

## INSTALLATION EXAMPLE

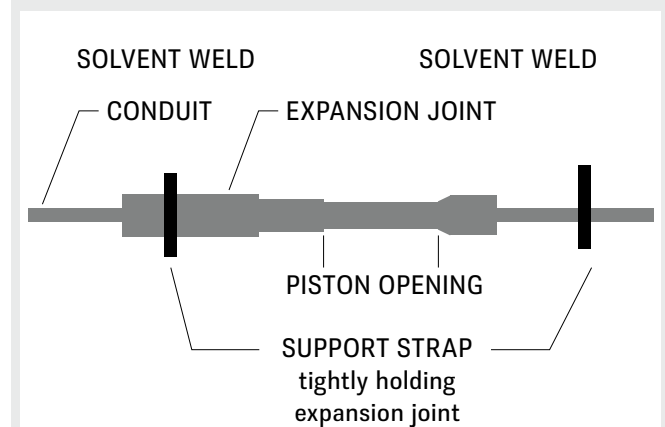

# INSTALLATION GUIDELINES FOR RIGID CONDUIT

## IF ONE EXPANSION JOINT IS REQUIRED

Securely fasten the barrel of the expansion joint close to one of the boxes. Support the conduit with straps, but allow free movement of the conduit for expansion and contraction. (See Drawing 1)

## IF TWO EXPANSION JOINTS ARE REQUIRED

There are two options available:

1. Firmly fasten one expansion joint near each end of the run and firmly fasten the conduit at the center. Support the rest of the conduit with straps allowing for movement of the conduit. (See Drawing 2)
2. Firmly fasten the expansion joints back-to-back at the center of the run. The conduit should be supported with straps to allow free movements as it expands and contracts. (See Drawing 3)

## IF THREE OR MORE EXPANSION JOINTS ARE REQUIRED

Evenly space the expansion joints along the run of Rigid PVC conduit. Tightly fasten each expansion joint and support the conduit with straps. Do not restrict the movement of the conduit.

\*For information on Maximum Recommended Spacing of Support Straps, see page 65.

### EXPANSION JOINT DRAWINGS 1-4

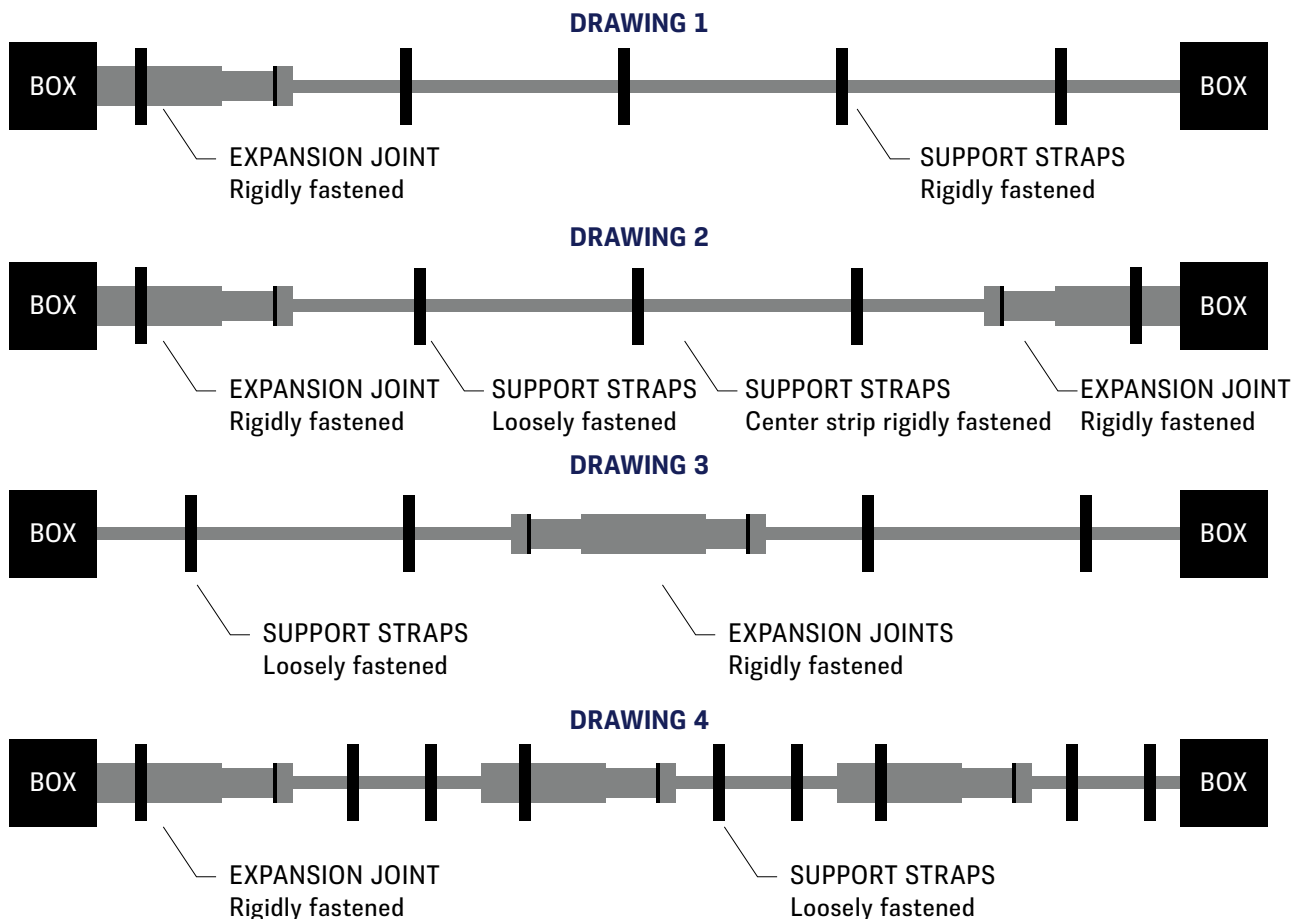

# INSTALLATION GUIDELINES FOR RIGID CONDUIT

## SPECIFICATION

All wiring shall be installed in Royal Electrical Solutions Rigid PVC Conduit and secured with proper fittings. All conduit and fittings shall be manufactured by Royal Building Products. All outlets, elbows and junction boxes shall be Royal products.

Exposed conduit shall be securely attached and supported with straps that are installed at the recommended spacing specified in the National Electrical Code, Article 352.30. Expansion fittings for PVC conduit shall be provided to compensate for thermal expansion and contraction where the length change is expected to be ¼ in or greater in a straight run between securely mounted items such as boxes, cabinets, elbows, or other conduit terminations in accordance with the National Electrical Code, Article 352.44.



## DIMENSIONS

NOMINAL SIZE	AVERAGE OUTSIDE DIAMETER (IN)	AVERAGE INSIDE DIAMETER (IN)	AVERAGE WALL THICKNESS (IN)	APPROX. WEIGHT LB/100FT
½"	0.840	0.608	0.116	16.1
¾"	1.050	0.810	0.120	21.5
1"	1.315	1.033	0.141	31.9
1¼"	1.660	1.362	0.149	43.8
1½"	1.900	1.592	0.154	52.3
2"	2.375	2.049	0.163	70.3
2½"	2.875	2.445	0.215	112.0
3"	3.500	3.042	0.229	146.7
3½"	4.000	3.520	0.240	176.4
4"	4.500	3.998	0.251	208.9
5"	5.565	5.017	0.274	283.4
6"	6.625	6.031	0.297	368.0

## SOLVENT CEMENT

### Rigid PVC Conduit and Duct Solvent Cement Low VOC/Premium Grade Clear

Royal Building Products Electrical Solutions offers two types of high performance solvent cement; low temperature for cold weather conditions, and cement for normal weather conditions. Our cold weather solvent cement can be applied in temperatures as low as -15°F in the harshest environments. Both of our solvent cement products are quick-drying to reduce installation time and save on labor cost. Royal's solvent cement provides a strong, reliable bond between pipe and fittings.

Solvent cement products can contain hazardous chemicals and volatile organic compounds (VOC), which emit smog-forming chemicals that can be harmful to users or installers and to our environment. Most of these products pollute indoor and outdoor air quality causing respiratory and eye irritation.

Our solvent cement products are Low VOC, resulting in lower emissions to the air and better health safety for individuals and installers who will be handling them.

Royal Building Products solvent cement meets or exceeds ASTM D2564 specifications for PVC solvent cements used in joining PVC piping systems, and is recommended for all classes and schedules of PVC pipe through 6", and through 4" for Schedule 80.